

USER MANUAL

ZK75 Series

Version 1.1 Date: September, 2017

Important Claim

Firstly, thank you for purchasing this hybrid-bio terminal. Before using, please read this manual carefully to avoid the unnecessary damage! The company reminds you that the proper use will improve the use affect and authentication speed.

No written consent from our company, any unit, or individual isn't allowed to excerpt, copy the content of this manual in part or in full, also spread in any form.

The product described in the manual maybe includes the software which copyrights are shared by the licensors including our company. Except for the permission of the relevant holder, any person can't copy, distribute, revise, modify, extract, decompile, disassemble, decrypt, reverse engineering, leasing, transfer, sub-license the software, other acts of copyright infringement, but the limitations applied to the law is excluded.

Copyrights

© Copyright 2017 ZKTeco Co, Ltd. All rights reserved.

All rights reserved. Except as specifically permitted herein, no portion of the information in this document may be reproduced in any form or by any means without the prior written permission from **ZKTeco**.



Due to the constant renewal of products, the company cannot undertake the actual product in consistence with the information in the document, also any dispute caused by the difference between the actual technical parameters and the information in this document. Please forgive any change without notice.

Safety Instructions

1. Read these instructions carefully. Keep these instructions for future reference.
2. Please disconnect this equipment from AC outlet before cleaning. Don't use liquid or sprayed detergent for cleaning. Use moisture sheet or cloth for cleaning.
3. Please keep this equipment from humidity.
4. Lay this equipment on a reliable surface when install. A drop or fall could cause injury.
5. Make sure power cord such a way that people cannot step on it. Do not place anything over the power cord.
6. All cautions and warnings on the equipment should be noted.
7. If the equipment is not used for long time, disconnect the equipment from main to avoid being damaged by transient over voltage.
8. Never pour any liquid into opening; this could cause fire or electrical shock.
9. If one of the following situations arises, get the equipment checked by a service personnel:
 10. The power cord or plug is damaged.
 11. Liquid has penetrated into the equipment.
 12. The equipment has been exposed to moisture.
 13. The equipment does not work well or you cannot get it work according to user manual.
 14. The equipment has dropped and damaged.
15. Do not leave this equipment in an environment unconditioned, storage temperature below -20°C or above 60°C, it may damage the equipment.
16. Unplug the power cord when doing any service or adding optional kits.

Lithium Battery Caution:

1. Danger of explosion can happen if the battery is incorrectly replaced. Replace only the original or equivalent type recommended by the manufacture. Dispose used batteries according to the manufacturer's instructions.
2. Do not remove the cover, and ensure no user serviceable components are inside. Take the unit to the service center for service and repair.

Table of Contents

1. Packing List	1
1.1 Standard Accessories	1
1.2. Optional Accessories.....	1
2. System View	2
2.1. Rear View.....	2
2.2. Side View.....	2
2.3. Front View.....	2
2.4. Back View.....	3
2.5. Specification.....	3
2.6. Internal Layout.....	4
3. Pin Definition.....	5
3.1. 2-Layer USB2.0 connector Pin Definition	5
3.2. 2-Layer USB3.0+2.0 connector Pin Definition	5
3.3. LAN: RJ45 Pin Definition	5
3.4. LINE-OUT JACK Pin Definition	6
3.5. VGA+USB+DC12V connector Pin Definition.....	6
3.6. VGA Pin Definition.....	7
3.7. LVDS connector Pin Definition.....	7
3.8. EDP connector Pin Definition:.....	8
3.9. DC Jack Pin Definition.....	9
3.10. RJ45(COM) connector Pin Definition	9
3.11. SATA: 22-pin SATA Pin Definition.....	10
3.12. Mini-PCIE Pin Definition.....	11
3.13. Int. Speaker Pin Definition.....	12
3.14. Touch Button for Power On/Off connector Pin Definition.....	12
3.15. NFC port connector Pin Definition.....	13
3.16. Sideward USB port connector Pin Definition.....	13
3.17. Front Panel function connector Pin Definition.....	14



3.18. RJ11(Cash Drawer) connector Pin Definition.....	14
4. System Assembly & Disassembly.....	16
4.1. HDD.....	16
4.2. Memory.....	16
4.3. MSR.....	17
4.4. VFD.....	17
4.5. 2 nd Display.....	17
4.6. Wi-Fi.....	18
5. Device Driver Installation.....	19
5.1. Resistive Type Touch Panel and P-CAP.....	19
5.2. MagSwipe Card Reader Configuration Utility.....	21
5.3. RFID.....	30
5.3.1. Install driver.....	30
5.3.2. Install framework 4.0.....	32
5.3.3. Quick Start with Demonstration Software.....	33
5.4. Configuration Utility of i-Button Reader Installation.....	34
5.5. VFD.....	37
6. BIOS/Utility setup.....	42
6.1 Advanced.....	43
6.1.1. Boot Configuration.....	43
6.1.2. Audio Configuration.....	44
6.1.3. Video Configuration.....	44
6.1.4. SATA Configuration.....	45
6.2. Security.....	45
6.3. Power.....	46
6.4. Boot.....	46
6.5. Exit.....	47
7. LCD Surface Cleaning.....	48

1. Packing List

1.1 Standard Accessories

<p>a.</p> 		<p>a. System (with stand) b. Power Adapter c. Power Cord d. Driver Bank</p>
<p>d.</p> 		

1.2. Optional Accessories

<p>a.</p> 	<p>b.</p> 	<p>a. Single MSR b. VFD c. 8"/10" 2nd Display</p>
<p>c.</p> 		

2. System View

2.1. Rear View

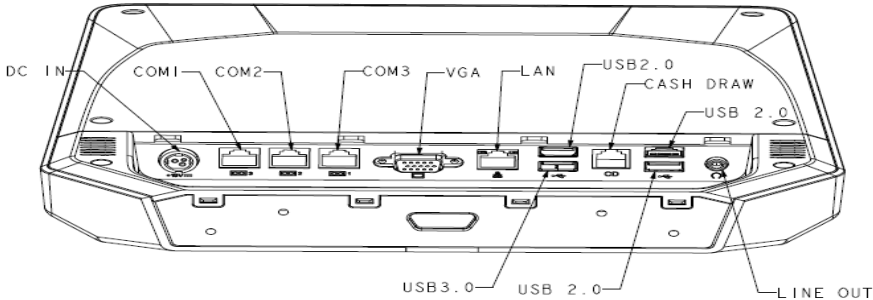

☆ Please make sure 19V DC plug in the left righdirection before plugging in DC jack.

2.2. Side View

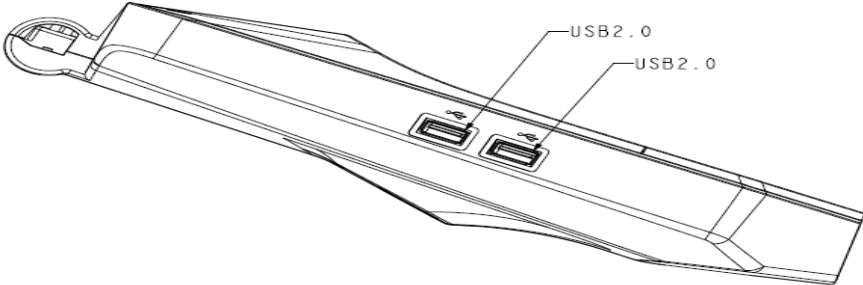

2.3. Front View

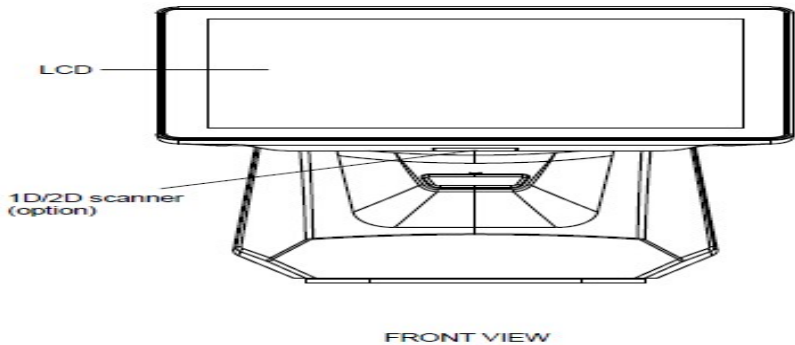

2.4. Back View

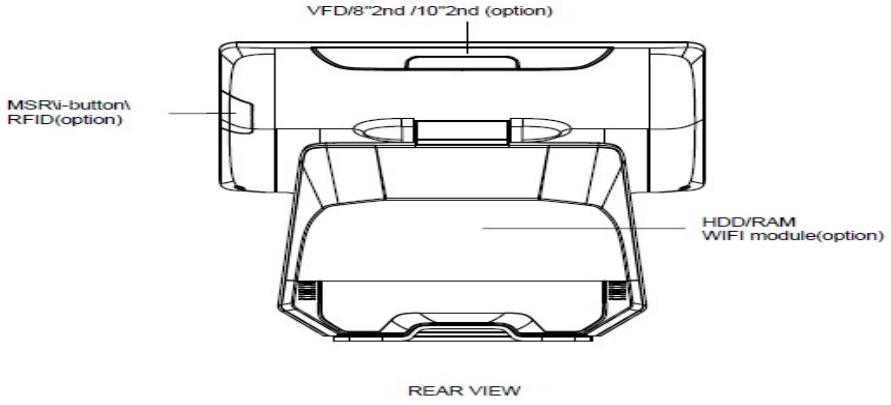

2.5. Specification

Processor	Intel® Celeron J1900 Quad Core 2.0GHz
Memory	One SO-DIMM socket supports DDR3L 1333 up to 8GB
Storage	2.5" SATAII HDD / SSD
Audio	Line-out
Network	RJ45 10/100/1000 Base-T
USB port	5*USB 2.0 / 1*USB 3.0
COM Port	3*RJ45
BIOS	Insyde BIOS
Power	AC 19V 90W Adaptor
Thermal Solution	Fan-less
Dimension	366 (W)x 377 (H) x265 (D)mm
Operating Temperature	0°C ~ 35°C
Storage Temperature	-20°C ~ 60°C
Storage Humidity	20% ~ 80%, non-condensing

Display		
	ZK7550	ZK7550W
LCD Panel Size	15-inch TFT LCD (LED Backlight)	15.6-inch TFT LCD (LED Backlight)
Resolution	1024*768 Pixels	1366*768 Pixels
Brightness	350 cd/m ²	250 cd/m ²
Touch Panel	5-wire Resistive Type / Projected Capacitive Type	

Note: Intel® Celeron J1900 CPU does not support POS Ready 2009

2.6. Internal Layout

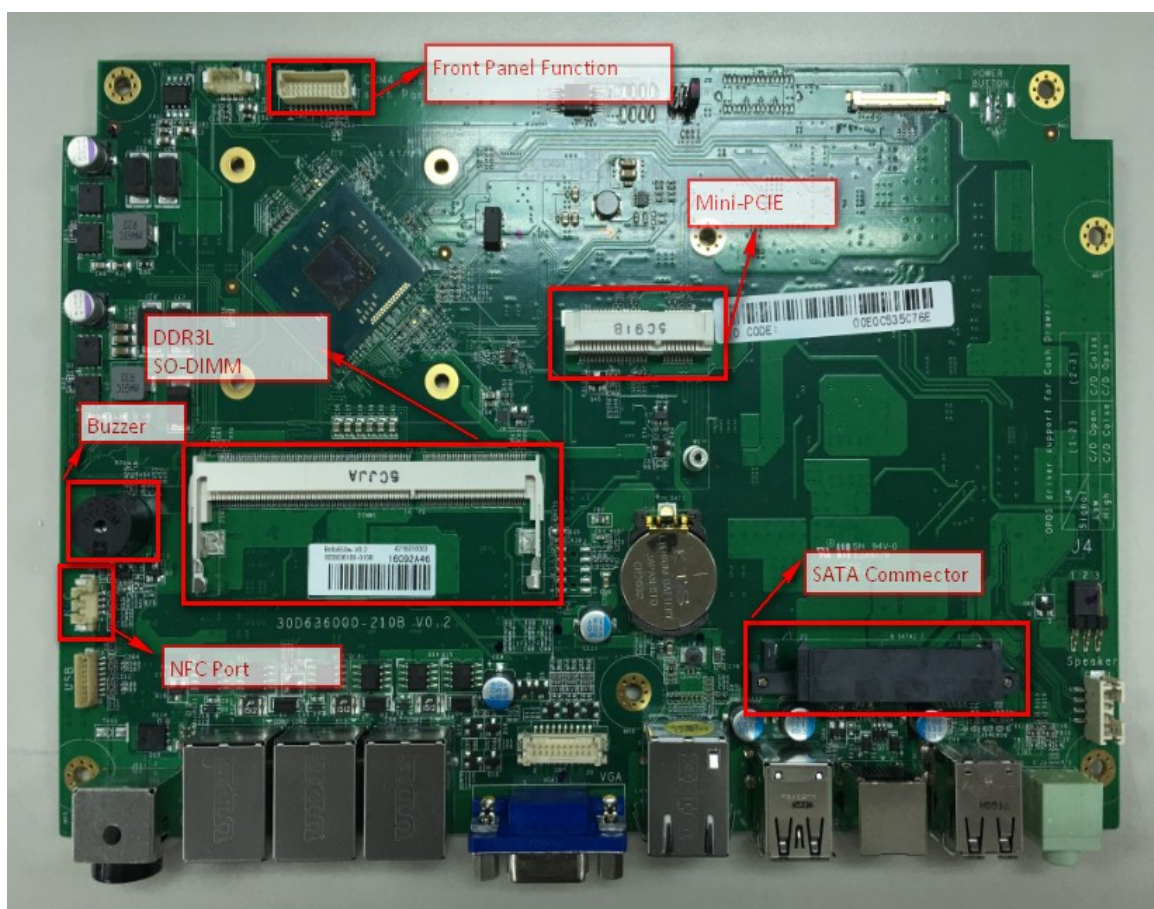

3. Pin Definition

3.1. 2-Layer USB2.0 connector Pin Definition

No.	Definition	No.	Definition
1	+5V	5	+5v
2	D-	6	D-
3	D+	7	D+
4	GND	8	GND

3.2. 2-Layer USB3.0+2.0 connector Pin Definition

No.	Definition	No.	Definition
1	+5V	8	TX-
2	D-	9	TX+
3	D+	10	+5V
4	GND	11	D-
5	RX-	12	D+
6	RX+	13	GND
7	GND		

3.3. LAN: RJ45 Pin Definition

No.	Definition
1	MDI0A+
2	MDI0A-
3	MDI1A+
4	MDI1A-
5	MDI2A+
6	MDI2A-
7	MDI3A+
8	MDI3A-

3.4. LINE-OUT JACK Pin Definition

No.	Definition
1	GND_AUD
2	GND_AUD
3	LINE_OUTR2
4	LINE_OUTL2
5	LINE2-JD

3.5. VGA+USB+DC12V connector Pin Definition

No.	Definition	No.	Definition
1	DDC_CLK	11	GND
2	DDC_DATA	12	RED

3	GND	13	GND
4	VSYNC	14	GND
5	GND	15	+12V
6	HSYNC	16	USB D-
7	GND	17	+12V
8	BLUE	18	USB D+
9	GND	19	Reserve for VGA +5V
10	GREEN	20	+5V

3.6. VGA Pin Definition

No.	Definition	No.	Definition
1	Red	9	N/C
2	Green	10	GND
3	Blue	11	N/C
4	N/C	12	I2C DATA
5	GND	13	HSYNC
6	GND	14	VSYNC
7	GND	15	I2C CLK
8	GND		

3.7. LVDS connector Pin Definition

No.	Definition	No.	Definition
1	+3.3V	2	+3.3V
3	+3.3V	4	+3.3V
5	GND	6	GND
7	DATA1-	8	DATA0-
9	DATA1+	10	DATA0+
11	GND	12	GND
13	CLK-	14	DATA2-
15	CLK+	16	DATA2+
17	GND	18	GND
19	N/C	20	DATA3-
21	Brightness	22	DATA3+
23	BKL enable	24	GND
25	GND	26	GND
27	LED Power +12V	28	LED Power +12V
29	LED Power +12V	30	LED Power +12V

3.8. EDP connector Pin Definition:

No.	Definition	No.	Definition
1	N/C	16	GND
2	GND	17	HotPlug Detect
3	N/C	18	GND

4	N/C	19	GND
5	GND	20	GND
6	TxD0-	21	GND
7	TxD0+	22	BKL enable
8	GND	23	Brightness
9	AUX+	24	N/C
10	AUX-	25	N/C
11	GND	26	+12V
12	+3.3V	27	+12V
13	+3.3V	28	+12V
14	N/C	29	+12V
15	GND	30	N/C

3.9. DC Jack Pin Definition

No.	Definition
1	+19V
2	Ground
3	+19V

3.10. RJ45(COM) connector Pin Definition

No.	Definition
1	+5V/+12V

2	DSR#
3	GND
4	DTR#
5	RST#
6	CTS#
7	TxD
8	RxD

3.11. SATA: 22-pin SATA Pin Definition

No.	Definition	No.	Definition
S1	GND	P1	N/C
S2	SATA_TX0_P	P2	N/C
S3	SATA_TX0_N	P3	N/C
S4	GND	P4	GND
S5	SATA_RX0_N	P5	GND
S6	SATA_RX0_P	P6	GND
S7	GND	P7	+5V
		P8	+5V
		P9	+5V
		P10	GND
		P11	GND
		P12	GND

		P13	N/C
		P14	N/C
		P15	N/C

3.12. Mini-PCIE Pin Definition

No.	Definition	No.	Definition
1	WAKE#	29	GND
2	+V3.3V	30	SMB__CLK
3	N/C	31	PCIE_TX_N
4	GND	32	SMB_DATA
5	N/C	33	PCIE_TX_P
6	+1.5V	34	GND
7	CLKREQ#	35	GND
8	N/C	36	USB D-
9	GND	37	N/C
10	N/C	38	USB D+
11	CLK_PCIE_N	39	N/C
12	N/C	40	GND
13	CLK_PCIE_P	41	N/C
14	N/C	42	N/C
15	GND	43	N/C
16	N/C	44	N/C

17	N/C	45	N/C
18	GND	46	N/C
19	N/C	47	N/C
20	W_DISABLE#	48	+V1.5V
21	GND	49	N/C
22	RESET#	50	GND
23	PCIE_RX_N	51	N/C
24	+3.3V_AUX	52	+V3.3V
25	PCIE_RX_P	53	GND
26	GND	54	GND
27	GND	55	GND
28	+V1.5V	56	GND

3.13. Int. Speaker Pin Definition

No.	Definition
1	Left Out +
2	Left Out -
3	Right Out-
4	Right Out+

3.14. Touch Button for Power On/Off connector Pin Definition

No.	Definition
-----	------------

1	+5V Standby
2	+5V Status
3	Power On#
4	GND

3.15. NFC port connector Pin Definition

No.	Definition
1	+5V
2	USB D-
3	USB D+
4	GND

3.16. Sideward USB port connector Pin Definition

No.	Definition
1	GND
2	USB D+
3	USB D-
4	+5V
5	GND
6	USB D+
7	USB D-

8	+5V
---	-----

3.17. Front Panel function connector Pin Definition

No.	Definition	No.	Definition
1	+5V	2	+5V
3	DSR4#	4	TxD5 for touch panel
5	DTR4#	6	RxD5 for touch panel
7	RTS4#	8	GND
9	CTS4#	10	+12V
11	TxD4	12	+5V
13	RxD4	14	+3.3V
15	GND	16	GND
17	+5V	18	+5V Standby
19	USB D-	20	+5V
21	USB D+	22	Power On#
23	GND	24	GND

3.18. RJ11(Cash Drawer) connector Pin Definition

No.	Definition
1	GND
2	C/D_OPEN#
3	C/D Status

4	+12V/+24V
5	N/C
6	GND

4. System Assembly & Disassembly

4.1. HDD



Note: Unscrew 4 screws and remove the base cover

Fasten HDD on HDD bracket with 2 screws

Install HDD with 2 screws

4.2. Memory



Put the memory into socket

4.3. MSR



1. Remove MSR cover
2. Install MSR holder with 2 screws
3. Plug MSR cable
4. Install MSR with 2 screws

4.4. VFD



1. Remove the Top cover
2. Plug VFD display cable
3. Install VFD with 2 screws
4. Cover the Top cover (with Hinge hole)

4.5. 2nd Display



1. Remove the Top cover
2. Plug 2nd display (VFD) cable
3. Install 2nd display with 2 screws
4. Cover the Top cover (with Hinge hole)

4.6. Wi-Fi



1. Put the WI-FI module into the Mini-PCIE Slot.
2. Connect 2 antennas on Wi-Fi module.(Notice: The antenna in black should be connected on position 1 of WI-FI module, and antenna in gray should be connected on position 2 of WI-FI module)
3. Put Wi-Fi module into socket with 1 screw

5. Device Driver Installation

5.1. Resistive Type Touch Panel and P-CAP

1. Click "Next".

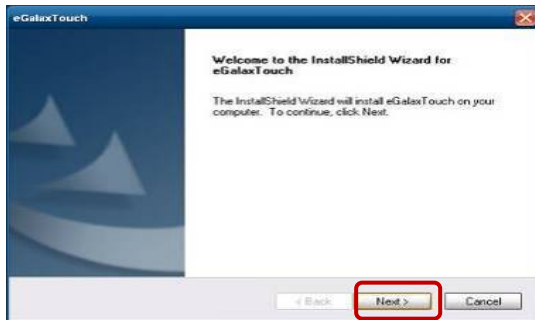

2. Click "Next".

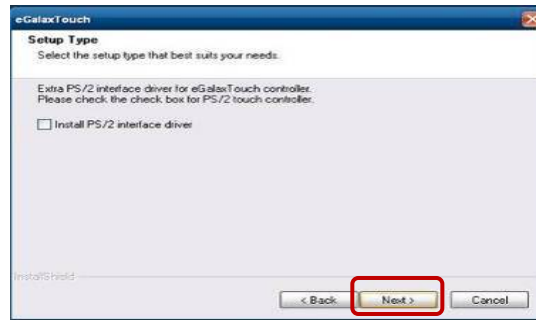

3. Click "Next".

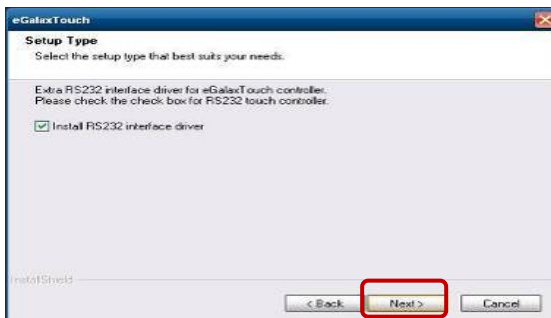

4. Select "None", Click "Next".

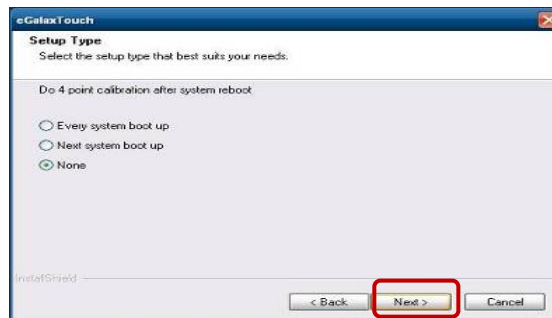

5. Click "OK".

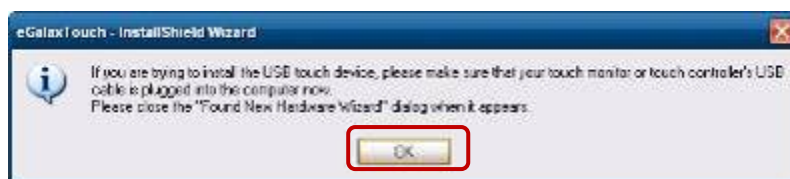

6. Select "Support Multi-Monitor System", Click "Next". 7. Click "Next".

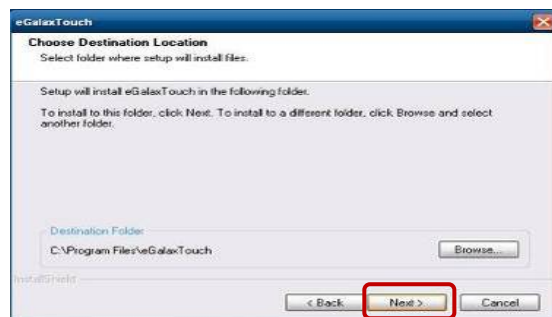
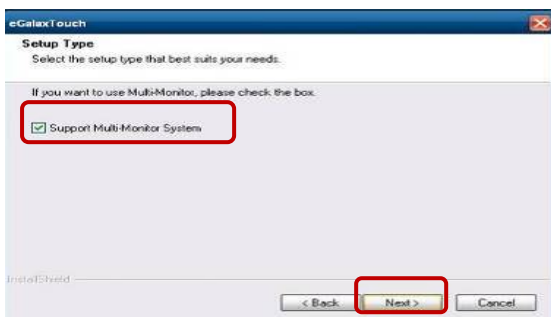

8. Click "Next".

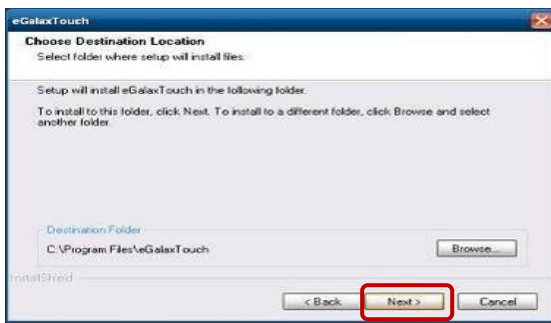

9. Click "Next".

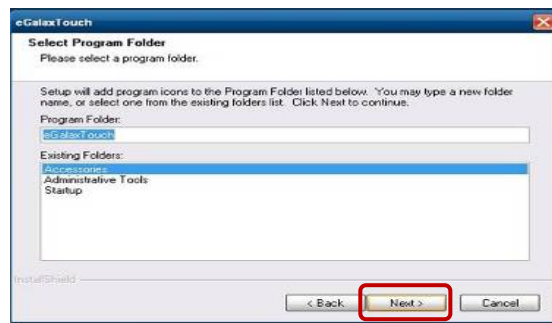

10. Select "Create a eGalaxTouch Utility shortcut on desktop", Click "Next".

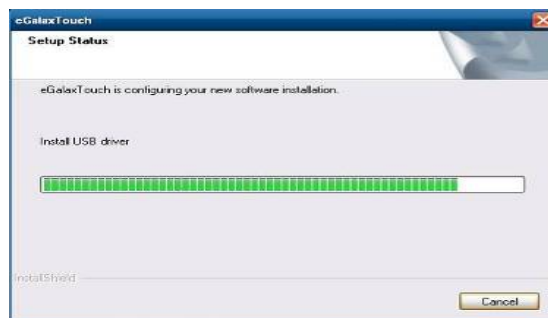
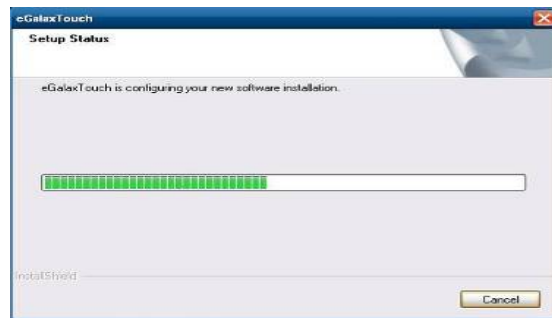
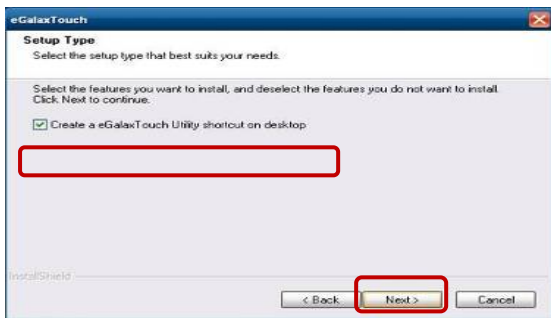

11. Would you do 4 point calibration now? Click "Yes".

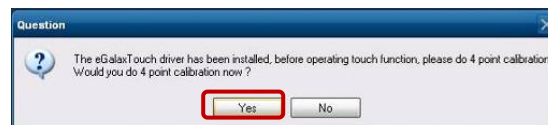

12. Do 4 points alignment to match display.

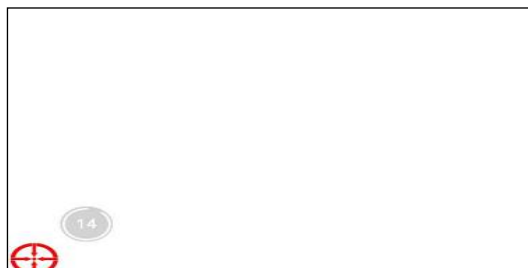

13. Calibration utility.



5.2. MagSwipe Card Reader Configuration Utility

The MagSwipe Configuration Utility is used to set up the output format of MagSwipe

- **Installation**

Below steps guide you how to install the Utility program

1. Insert the setup CD
2. Run the 80066804-006_Magswipe_Configuration_Software_V2_1_A setup file that is located in the Software folder of CD.
3. Follow the wizard to complete the installation.

- **Launching Program**

Below steps guide you how to load the Utility program.

1. From Start/Programs, click MagSwipe folder
2. Click MagSwipe Configuration Utility to launch the program.



- Configuration



1. Select Reader Interface

The reader to be configured should be connected. Select the corresponding connected reader interface and click the Continue button

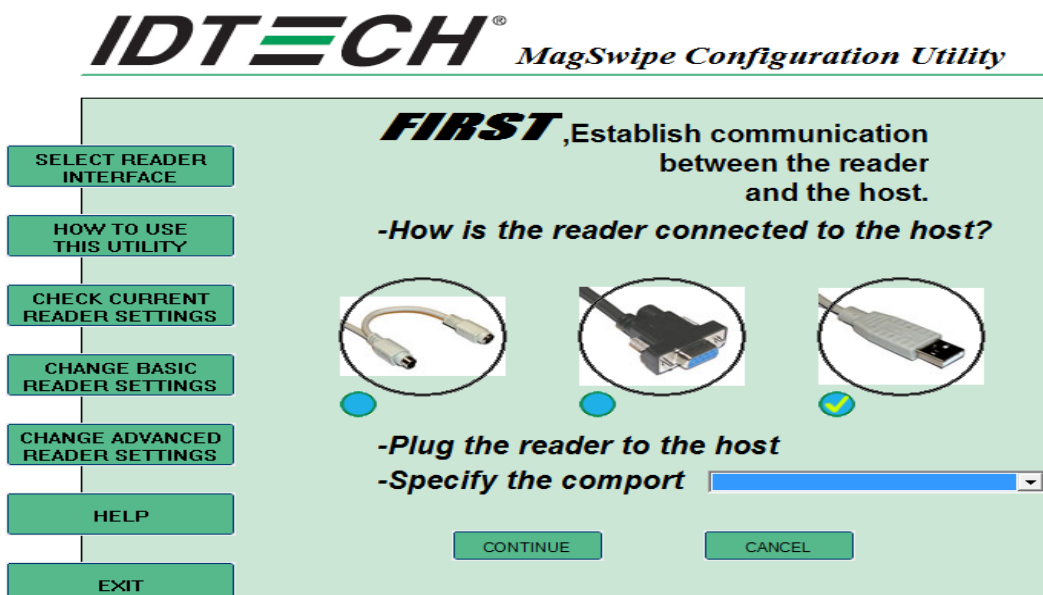

After the interface selection is made, click the Continue button. The utility attempts to communicate with the connected reader. If successful, the Home Menu Page is displayed. The Home Menu Page is shown below



2. Change Basic Reader Setting

After selecting the appropriate interface for the reader, select one of the Home Menu Page buttons to proceed with the Magnetic Stripe Reader (MSR) configuration process. The "Basic Reader Settings" group defines the basic operating parameters and data output format of the reader.

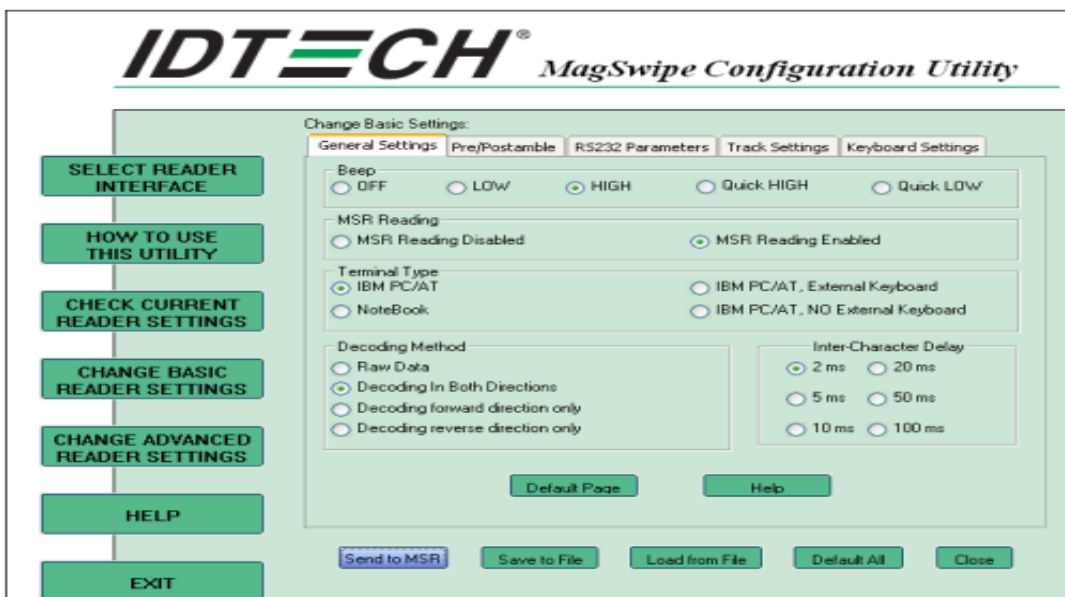

- Button Definitions

1. Send To MSR

When all the setting parameters are selected, use the "Send To MSR..." button to send configuration data to the reader device. When the reader has received the data correctly, the settings take effect immediately.

2. Load From File

The configuration data can be loaded into the configuration utility from a file that has been previously saved. Select this command, start a "File Open" dialog, which allows selection of the file.

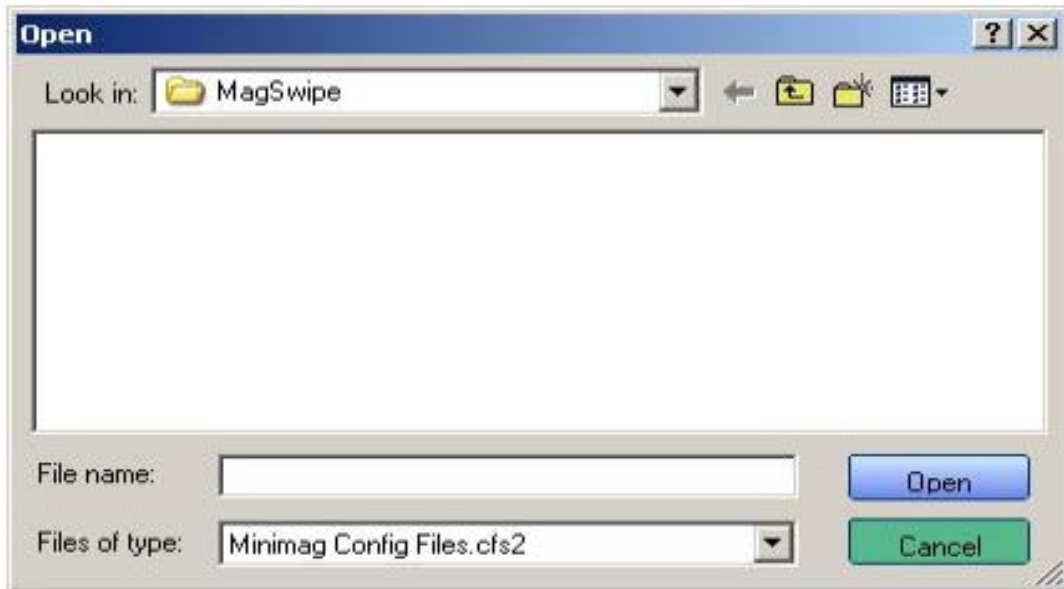

3. Save To File

The configuration data can be saved as a file and being used later to configure other readers. When saving a configuration the "File Save" dialog is opened as shown below. Input a filename and file location.

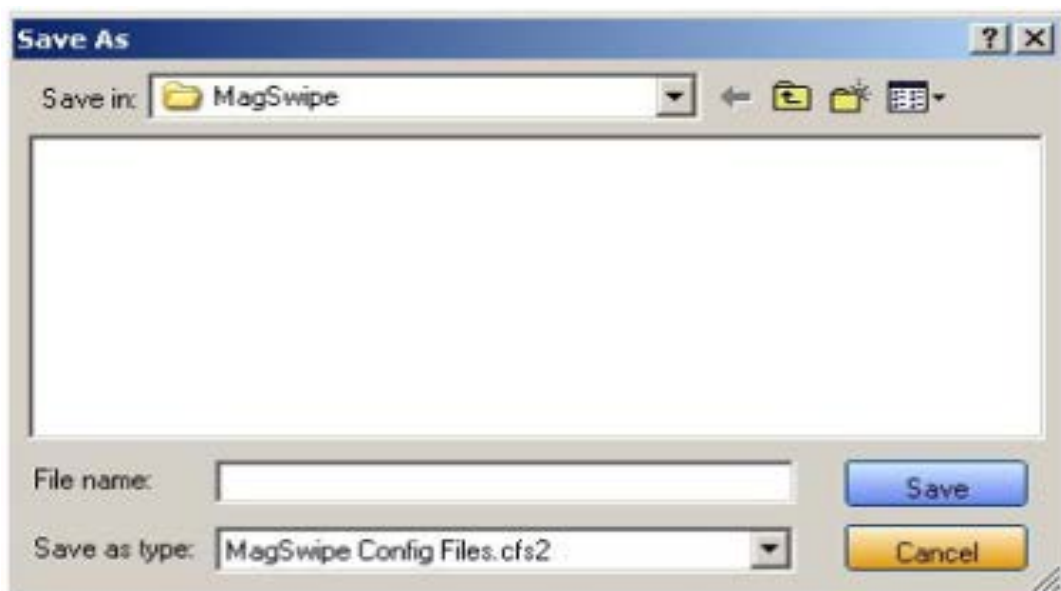

4. Default All

This button sets the reader with the default configuration parameters (the default factory settings). The settings take effect immediately. The default parameters affect all reader configurations settings.

5. Close

Close this dialog and return to the Home Menu Page.

- General Settings

This group of configuration settings defines the basic operating parameters of the reader.

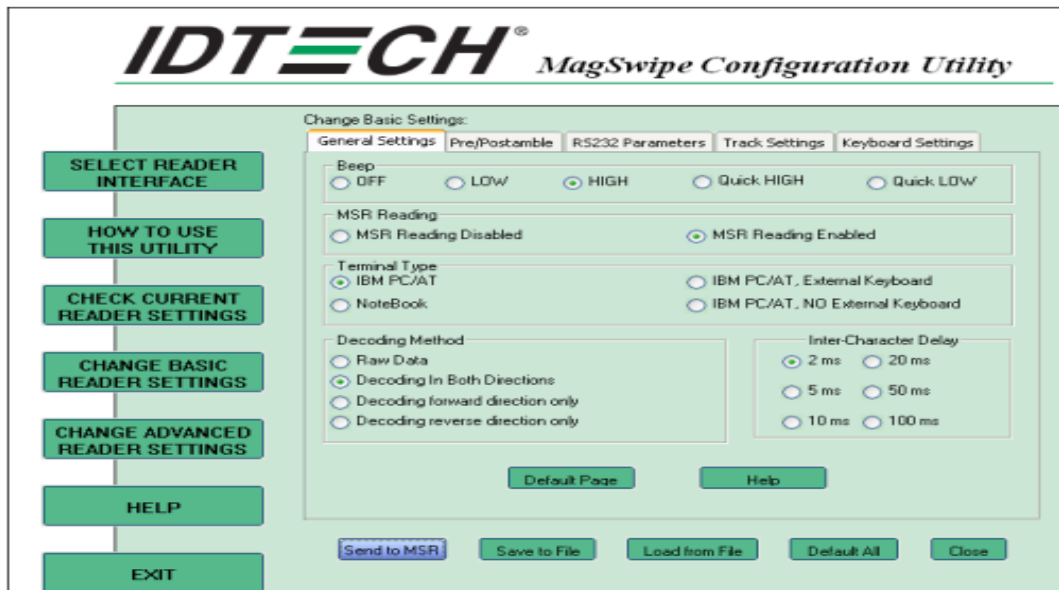

1. MSR Reading

This option will turn on or off the MSR. If MSR is disabled no data is sent out to host in any case. The default is MSR Reading Enabled.

2. Decoding Method Settings

This option gives four kinds of decoding methods.

Raw Data (output in both forward and reverse directions)

Decoding in Both Directions (forward and reverse reading)

Decoding in Forward Direction only (card entering slot from LED end)

Decoding in Reverse Direction only (card entering slot from end opposite LED)

With the bi-directional operation, the user can swipe the card in both swipe directions and the data encoded on the magnetic stripe will be output. In the single swipe direction selections, the card can only be

swiped in one specified direction to read the card. The default setting will decoding card data with the card swiped in either the forward or the reverse direction.

"Raw Data" is an output of the decoded magnetic stripe data in hexadecimal format (no ASCII character conversion is performed). In the Raw Data setting, the reader outputs all track-decoded data. The MSR will represent the raw data with two ASCII characters: the first ASCII character is for high bits of the raw data byte and the second is for the low bits. For example, the two ASCII characters "4" and "1" represent raw data byte 41h(01000001).

3. Beep Volume

The Beep volume can be adjusted to four loudness levels or off. Four loudness levels are:

- a. Quick High
- b. Quick Low
- c. High
- d. Low
- e. The default is High beep.

4. Terminal Type

- a. NoteBook
- b. IBM-PC/AT
- c. IBM-PC/AT, External keyboard
- d. IBM-PC/AT, No External keyboard
- e. The firmware can be programmed to interface as a keyboard wedge to 4 different types of terminals. The default is IBM-PC/AT.

5. Inter-Charater Delay :

2ms, 5ms, 10ms, 20ms, 50ms, 100ms;

This is the time period the reader will delay between sending successive characters. Some terminals or computers (host) require an inter-character delay to simulate the effects of keystroke delays. Choosing a longer inter-character delay causes the characters to be sent at a slower rate. If the host system is not capable of receiving characters as fast as the reader can transmit, setting an appropriate inter-character delay will keep the reader from overrunning the host input buffer. The default is 2ms.

6. Default Page Button

After you click the Default Button, the general settings page will change back to the default value. Settings are not sent to MSR until the "Send to MSR" button is clicked.

7. Help Button

Click the help button to open the help index for this section.

- **Pre/Postamble**

1. Preamble

Characters can be added to the beginning of the reader's output string of data. These can be special characters for identifying a specific reading station, to format a message header expected by the receiving host, or any other character string. Up to nine ASCII characters can be defined for the Preamble.

2. Postamble

The Postamble serves the same purpose as the Preamble, except the extra characters are added to the end of a data string. The Postamble can be added only after a terminator character, if specified.

3. Track Prefix and Suffix

For some Host applications, it may be convenient to start or end a string of reader data with a Sentinel or terminator character. The maximum Prefix/Suffix string is six characters and its default is NULL (no prefix or suffix).

4. Track Start Sentinels

Characters can be added to the beginning of each track data string to simulate the start of the track data. These can be special characters for identifying a specific track.

5. End Sentinel

The magnetic stripe End Sentinel character can be added to the end of a magnetic stripe data string. This character simulates the end of character for track1, track2 or track3. This default is '?'

- **Track Settings**



1. Track Selection

There are three tracks of info

rmation possible on a magnetic stripe. This option selects the tracks that will be decoded (read). Note that the magnetic stripe reader must have the hardware configuration (read head and circuits) for reading the specified tracks. If a single or dual track reader is used, the heads must be positioned to read the tracks selected by this option. The default is Any Track.(All tracks written on the card will be read).

2. Track Separator Selection

This option allows the user to select the character to be used to separate data decoded by a multiple-track reader. The default value is CR

3. Send Start/End Sentinel

The reader can send the Start/End sentinel for a track, decoded without error.

4. Send LRC in Card Data

The reader can send the track LRC for a properly decoded track.

For Track 2 only Send Account Number

The reader can only send account Number if it is true. And if it is false, the reader sends all Track 2 data.

5. Send Error Indication

This option let reader to send out [SS]E[ES] if failed to read or missing data on a selected track.The default is off.

The error output for track 1 is "%E?".

The error output for track 2 is ";E?".

The error output for track 3 is "+E?".

- **Keyboard Settings**

There are keyboard settings information on a magnetic stripe. MiniMag II will support following foreign language keyboard and function key output for PS/2 and USB HID Keyboard Interface.

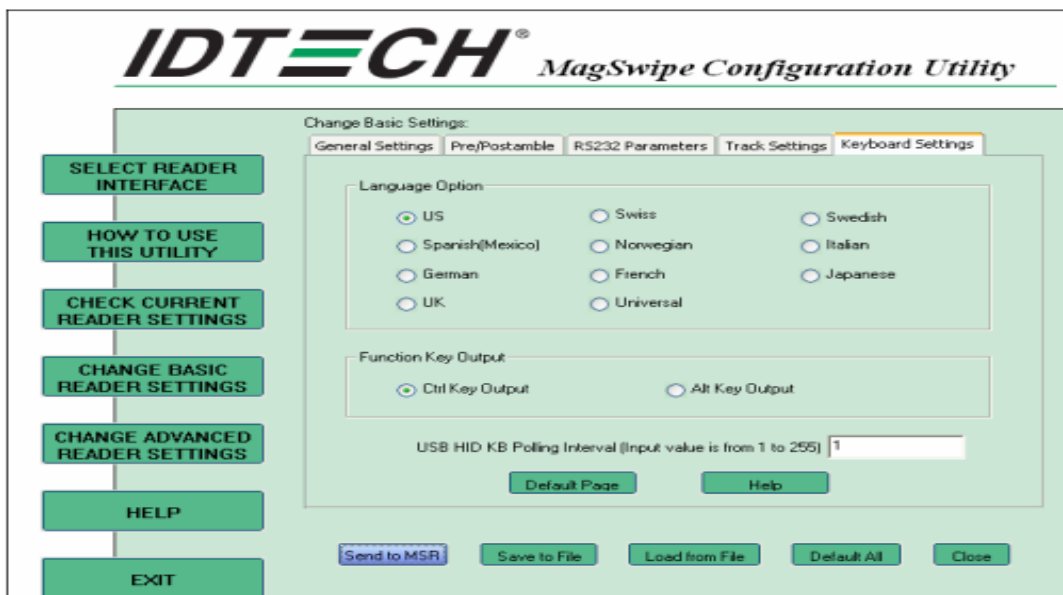

1. **Language Option**

This option allows the user to select the keyboard language of US, Swiss, Swedish, Norwegian, Italian, Spanish(Mexico), German, French, Japanese, UK and Universal. Universal language sends out all the data as a series of ALT keyed sequence.

2. **Function Key Output**

The function key output be used to support the special key to delay card data output.

3. **USB HID KB Polling Interview**

The user can input the number between 1 to 255 for the delay of output.

4. **Check Current Reader Setting**

After you connect the device, the current reader configuration can be displayed by selecting this button.
The configuration data of the connected reader will be displayed like in the example:

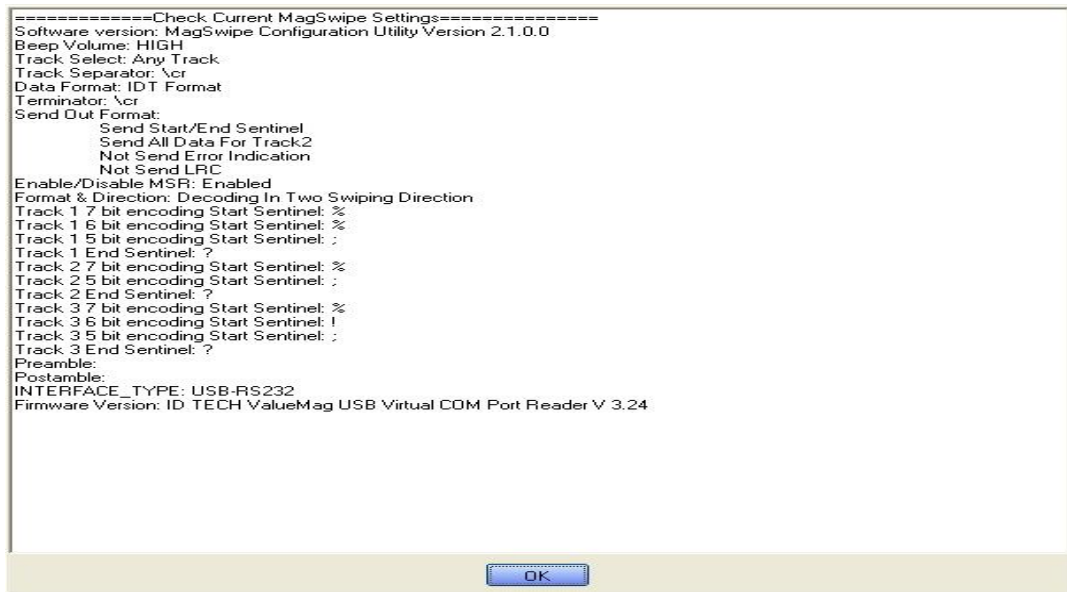

5.3. RFID

5.3.1. Install driver

1. Check the Device Manager to verify the status of RFID reader.

Computer Management -> Device Manager -> Other devices (The device will show a question mark if the installation is not done properly.)

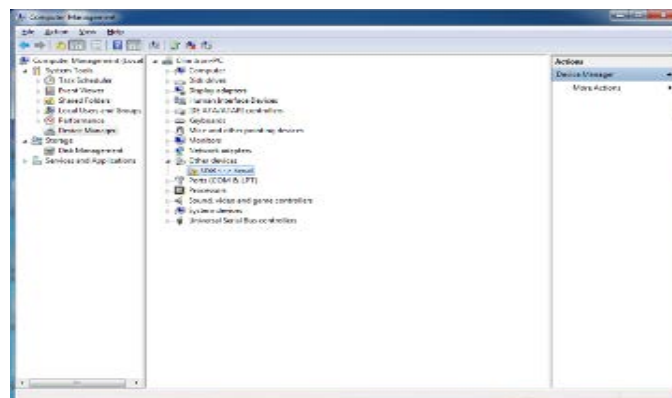

2. Double-click to Update driver.

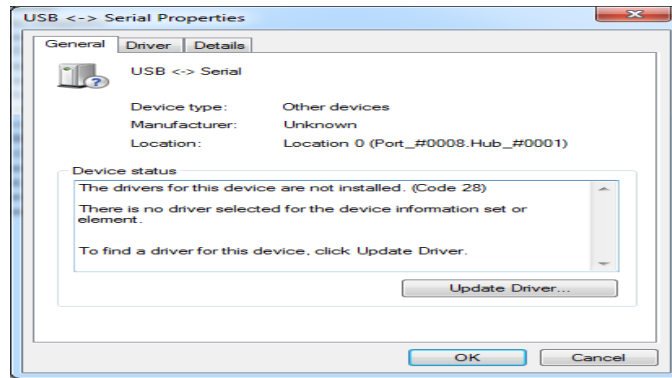

3. Select "Browse my computer for driver software."

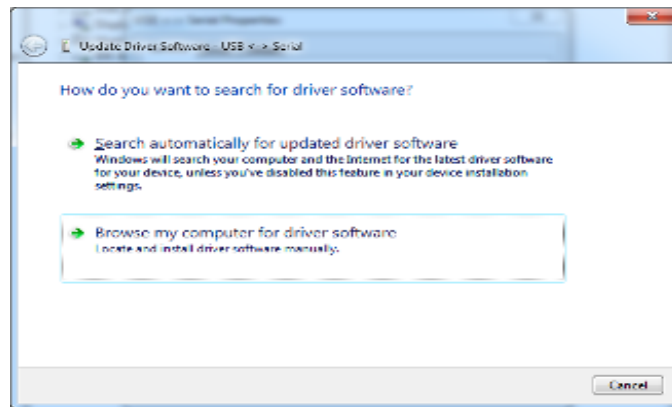

4. Click Browse to select file called HFF320U \Driver\FTD\x64, and click **Next**.

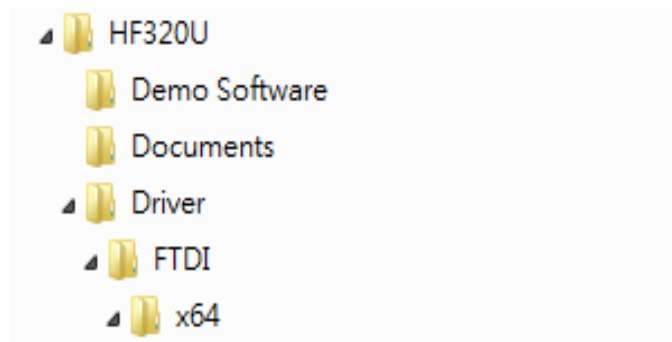

5. Install the driver

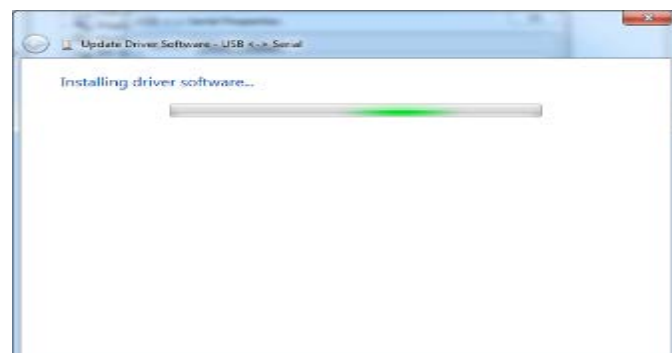

6. Install complete and then click “close”

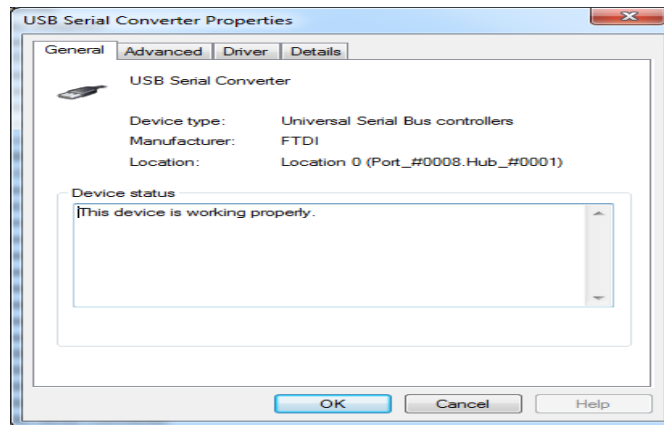

7. Restart the computer



5.3.2. Install framework 4.0

1. Double-click to install.

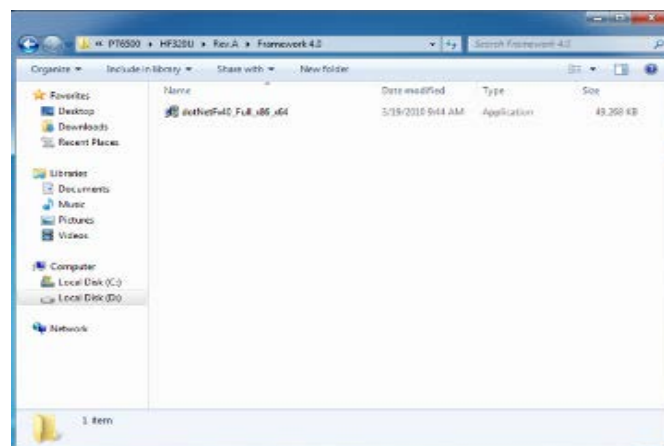

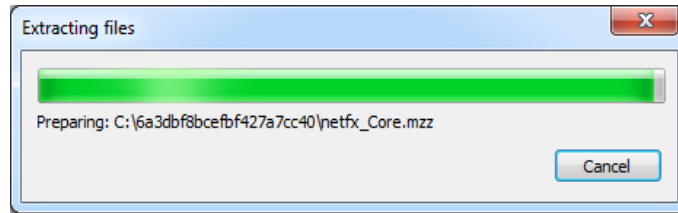

2. Select "I have read and accept the license terms". And click "Install".

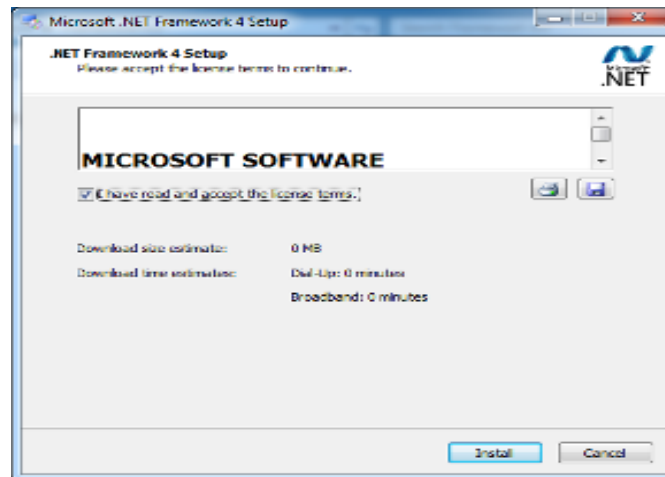

3. Click "Finish".

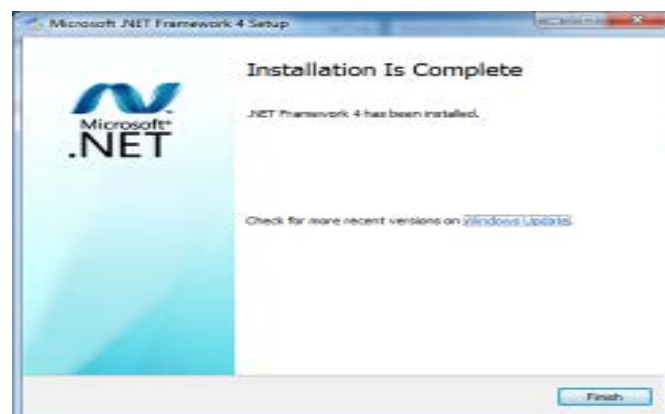

5.3.3. Quick Start with Demonstration Software

1. The demonstration software is "MP Studio.exe" provided in the folder "Demo Software". There is no software setup required; just double click the "MP Studio.exe". The demonstration software can run either from CD or a copy on hard drive. The GUI of software is shown in below picture and ready to use.

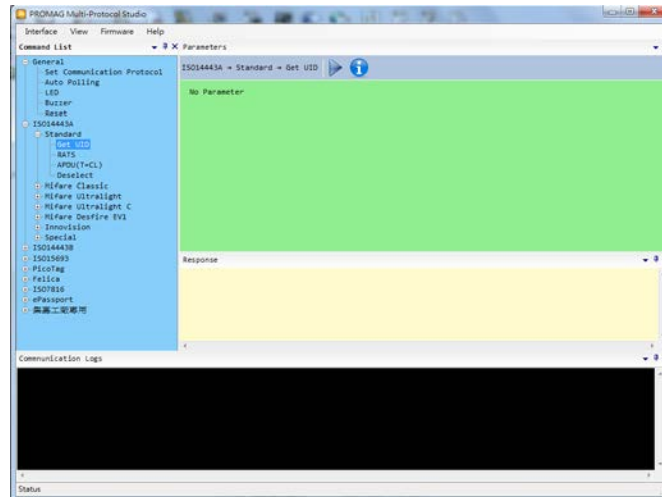

2. Following steps, as shown in below picture, demonstration a simple usage in reading UID of ISO14443A card for quick understanding.

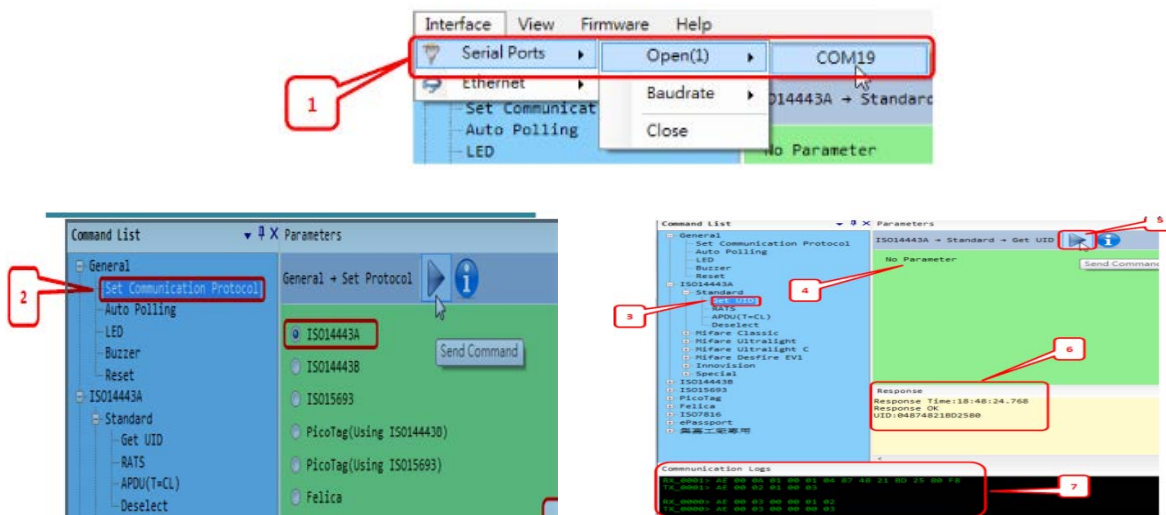

5.4. Configuration Utility of i-Button Reader Installation

Below steps guide you how to install the Utility program.

- Insert the setup CD
- Run the ZKTeco IButton Utility.exe setup file that is located in the Software folder of CD
- Follow the wizard to complete the installation.

1. Setup ZKTeco Button_V1.0.exe software

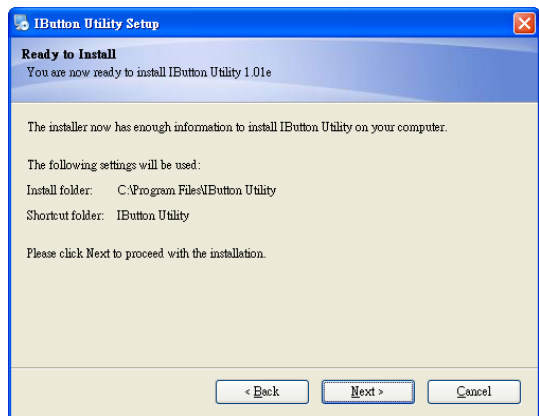
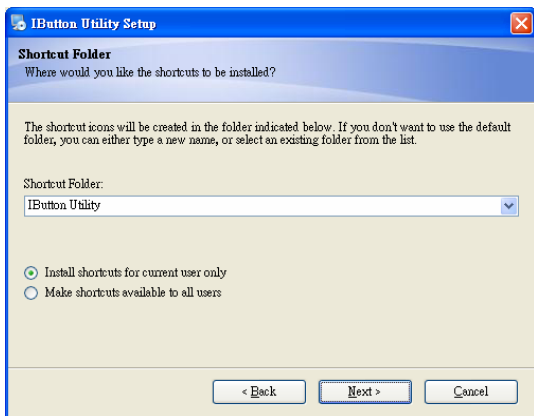
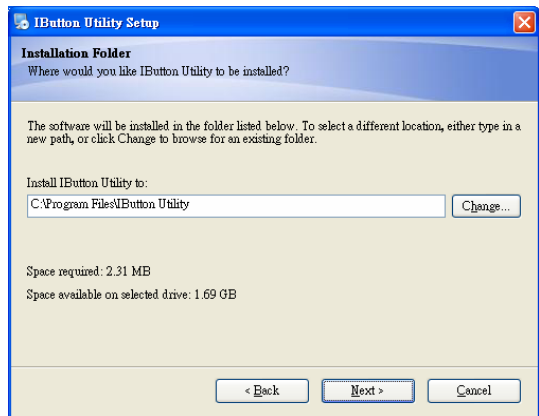
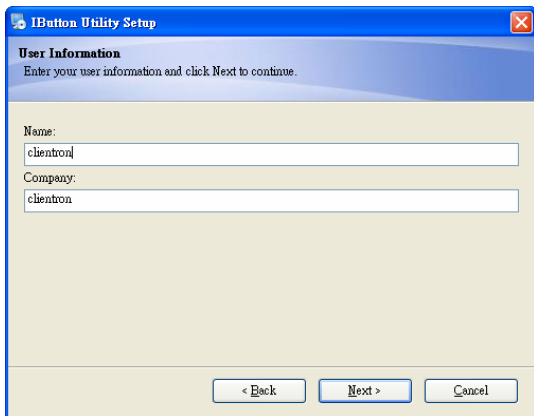
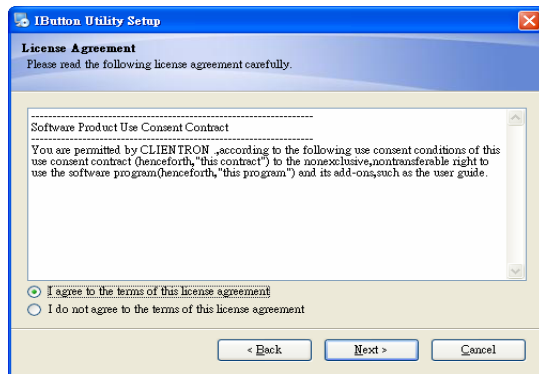

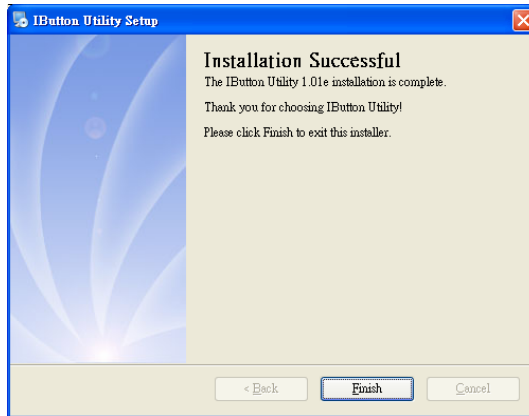

2. To execute "IButton_V1.0.exe" for setup communication between software and IButton module.
 The utility program will detect the connected reader. If detected, all the input text boxes will be enabled.
 If the reader has not been connected to PC yet, please connect the reader and then click Refresh to get connected.

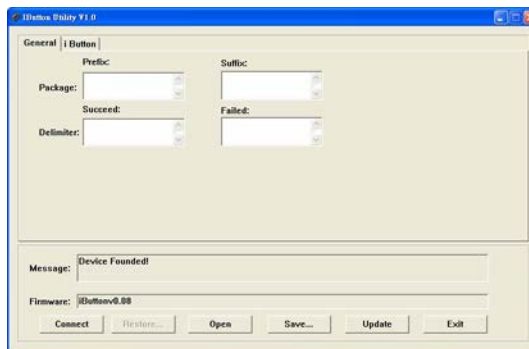

- Configuration

Below is the main window of i-Button Utility program.

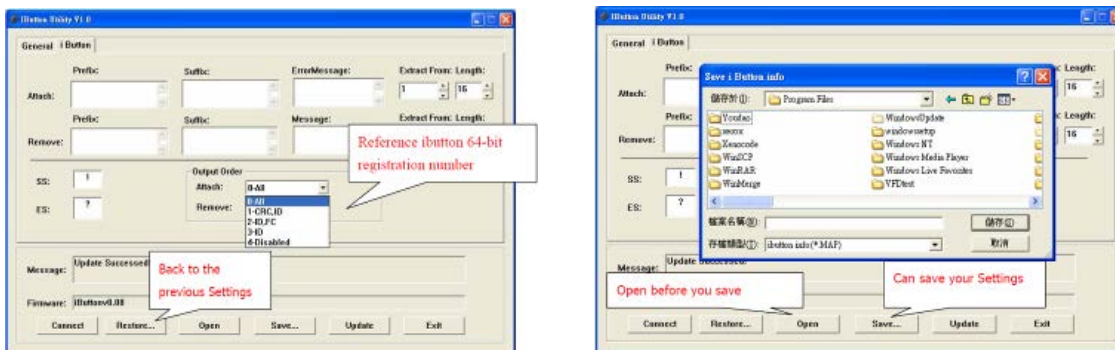

- For the settings, there are:

Prefix/Suffix: Defines the data string which you would like to append in front or end of the i-Button key

string.

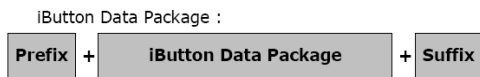

1. Error Message: Indicates error message when i-Button key read fail.
2. Message: Indicates message when i-Button key read correctly
3. SS/ES : Define Start and End sentinel byte for the i-Button ID string

- **iButton data format:**

- **SS + iButton 64- Bit Registration Number + ES**

1. Length : i-Button ID length request from 0~16
2. Output order : 4 formats could be select at Attach /Remove i-Button ID

- **iButton 64- Bit Registration Number:**

- **8-Bit CRC + 48-Bit ID + 8-Bit FC**



DEMO SETUP&OUTPUT

OUTPUT DATA :

alab00000003bdfa01?

blab00000003bdfa01?

5.5. VFD

1. Power on VFD and waiting test page of EEPROM test, Baud rate and Command page. Set up the customer display by "VFD set.exe"

2. Setup VFDset.exe software.

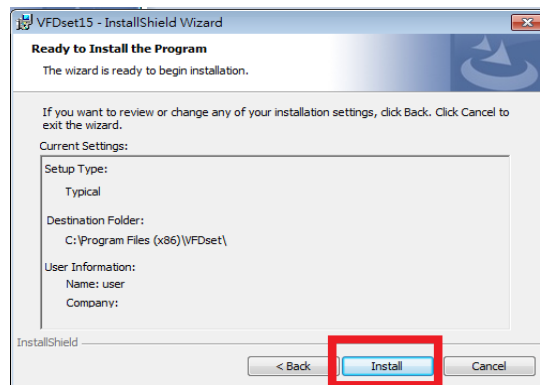
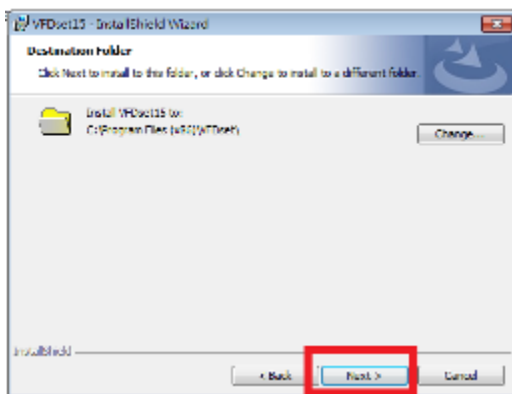
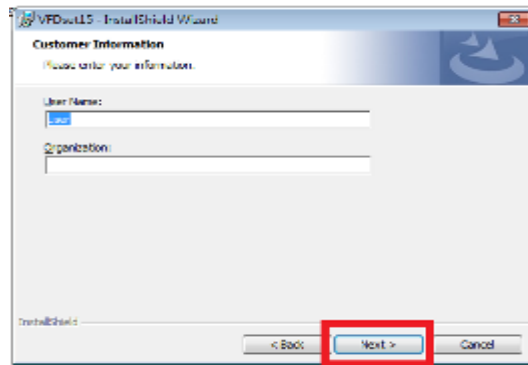

6. To execute "VFDset.exe" for setting up communication between software and VFD module.

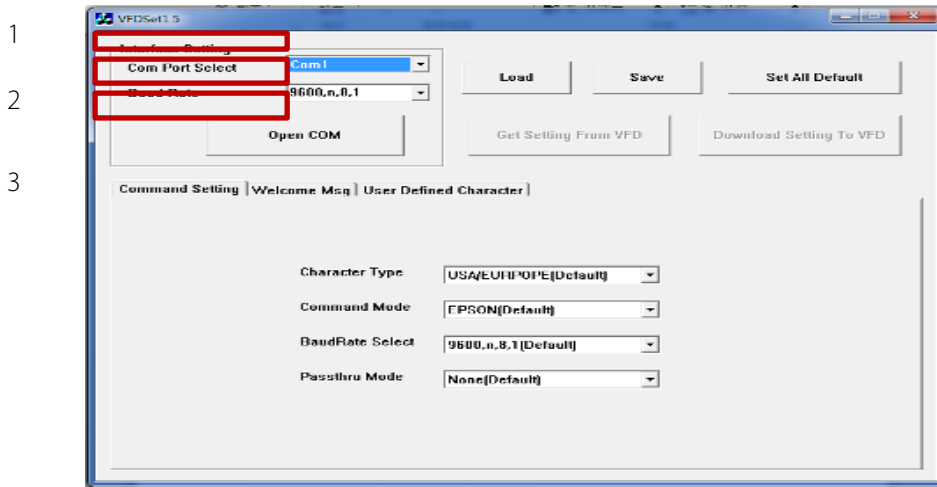

Please then follow the steps as shown in the above figure, the baud rate will show on states page of VFD module (Note: You may check it when power on VFD module), then click "Open COM" button.

7. "Get Setting from VFD" button to get all the settings from ZKTeco and it'll refresh the "VFDset.exe" software.

8. Select "Character Type"/"Command Mode"/"Baud Rate Select"/"passthru Mode".

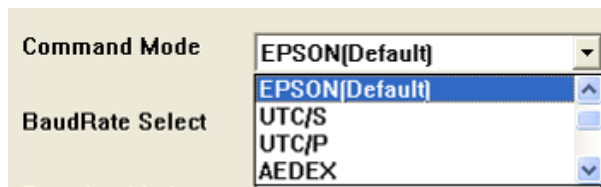

9. Click "Set All Default" button to show default setting, the Default table is

Character Type : USA

Command Type : EPSON/EUROPE

Baud Rate Setting : 9600/n/8/1

Pass-through Mode : None

Welcome msg line1 : *** VFD DISPLAY ***

Welcome msg line2 : **HAVE A NICE DAY AND THANK YOU **

7. Welcome Message

Welcome Message line1 maximum 20 characters, line 2 maximum 20 characters, total of 40 characters.

- ASCII mode

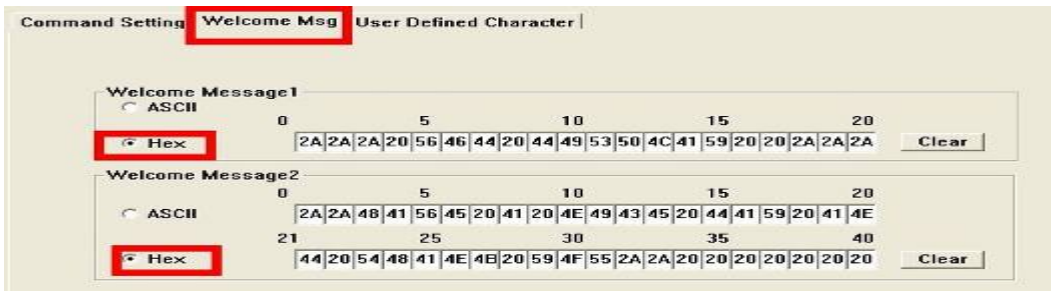

You can type the character by keyboard (0x20h ~ 0x7Fh), if you press clear icon, it will clear the all Message characters on AP.

- Hex mode

Hex mode can define the character from 0x20h to 0xFFh, the range 0x80~0xFF which depends on the code page table.



Like the first character (0x80), in default code page will show on VFD module.

8. Click "Download setting to VFD" button

This button is to download the setting from VFDset.exe to VFD module. After success dialog "Download O.K!"

Please restart!" message popped up. Please restart display for enable new setting



9. Click "Save" button

To save user's setting in file; for example, below picture to save file name as "GOODLUCK" file set for Welcome Message.

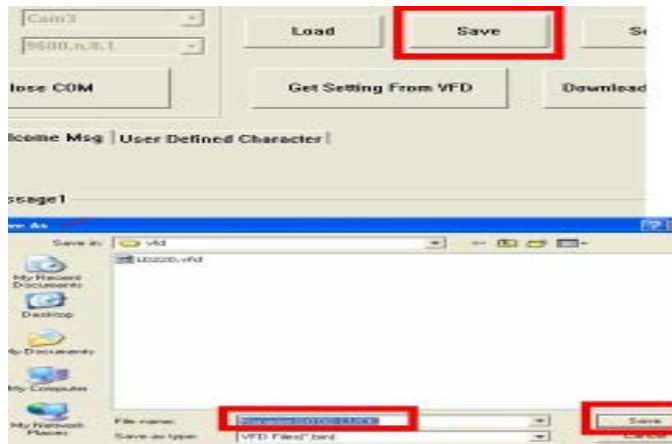

10. Click "Load" button

After saving, you must restart the utility here. Then load your setting rename-GOOD LUCK.vfd.

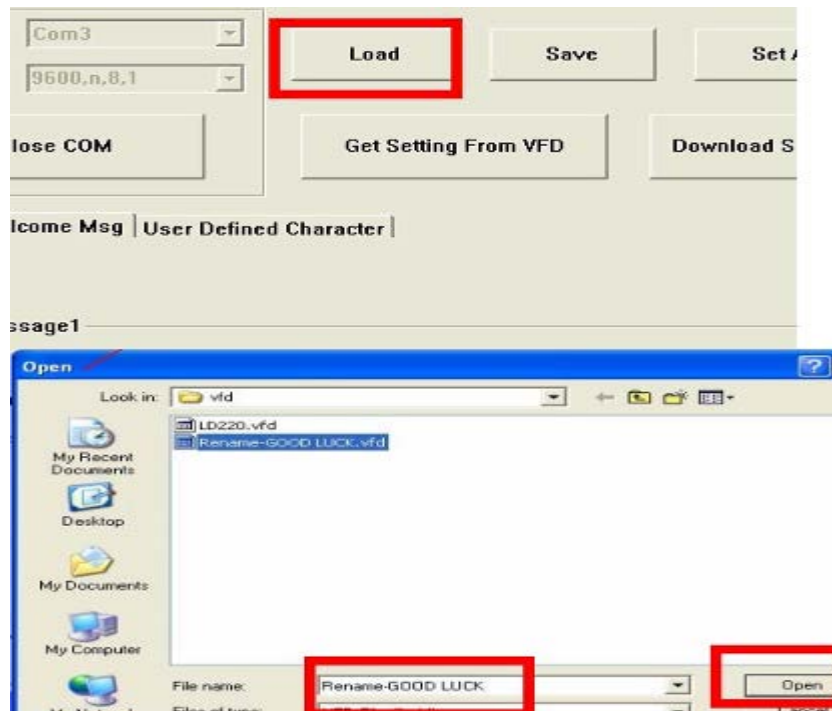

6. BIOS/Utility setup

Press key to enter SETUP CMOS UTILITY when system boot up.

1. Please press key tenderly and slowly.

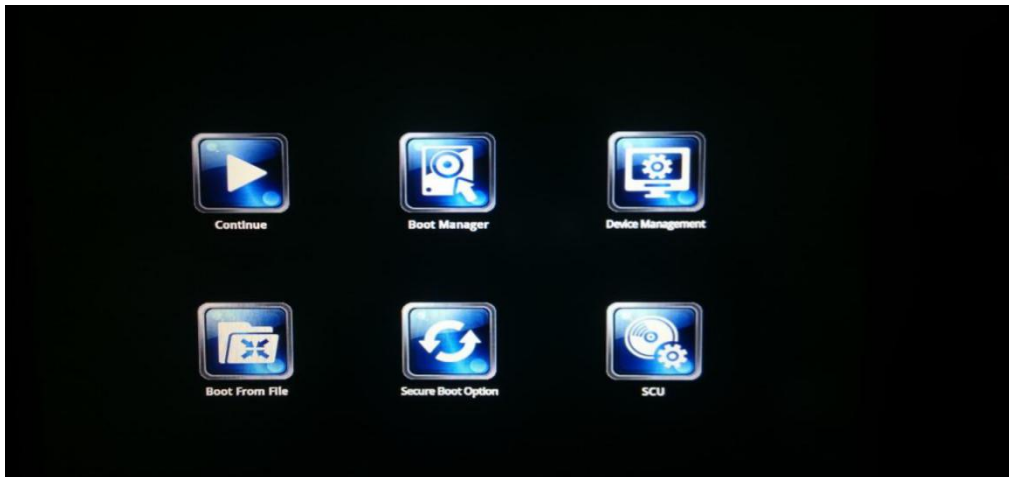

2. Please press <ENTER > over SCU Button key.

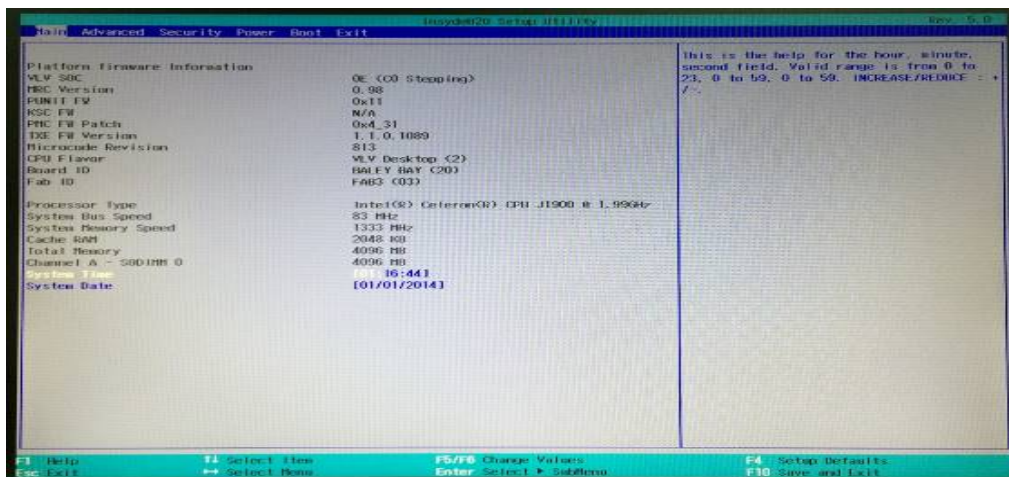

3. Press <F9> to view the system information

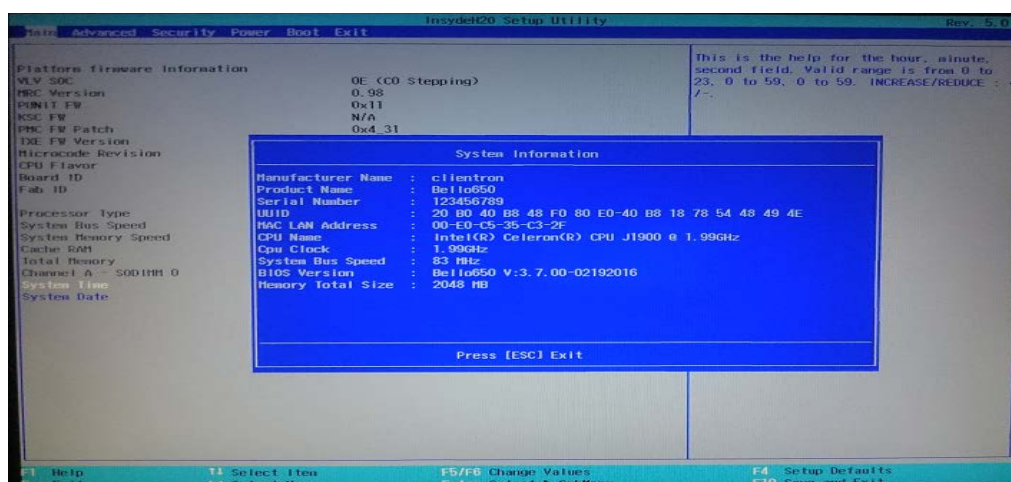

- **Date and Time**

The Date and Time items show the current date and time on the computer. If you are running a Windows OS, these items are automatically updated whenever you make changes to the Windows Date and Time Properties utility.

- **WARNING!**

Setting the wrong values in the sections below may cause the system to malfunction. Make sure that the settings made are compatible with the hardware.

6.1 Advanced

Use the Advanced menu to configure the system for basic operation through the following sub-menus:

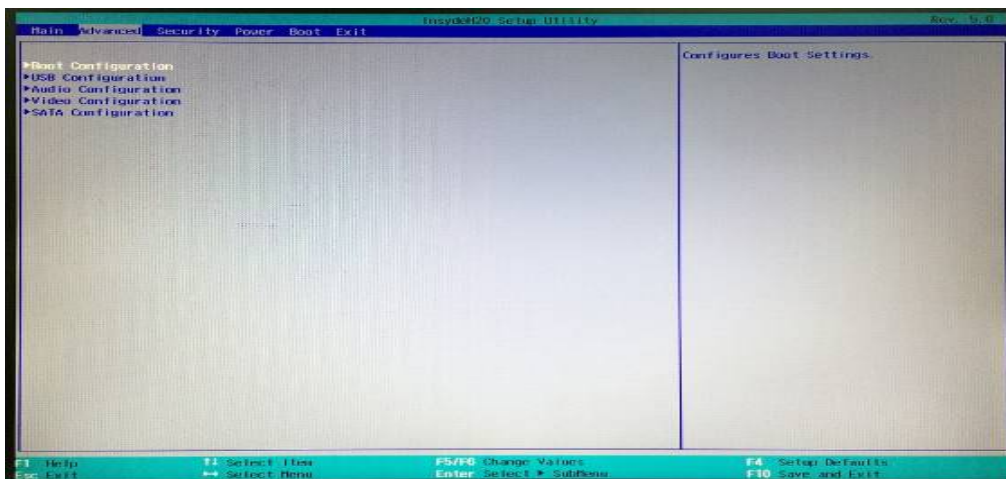

6.1.1. Boot Configuration

Use the Boot Configuration menu to select power-on state for Num lock.

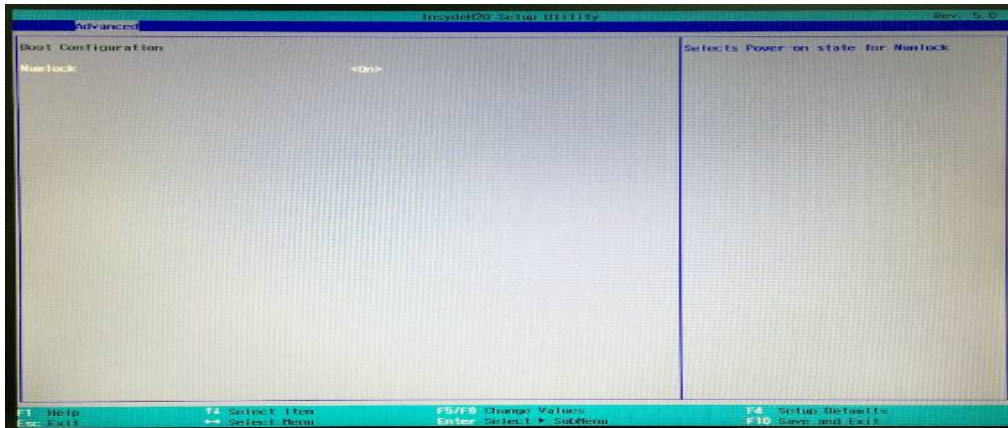

6.1.2. Audio Configuration

Use the Audio Configuration menu to read Audio configuration information and configure the Audio settings

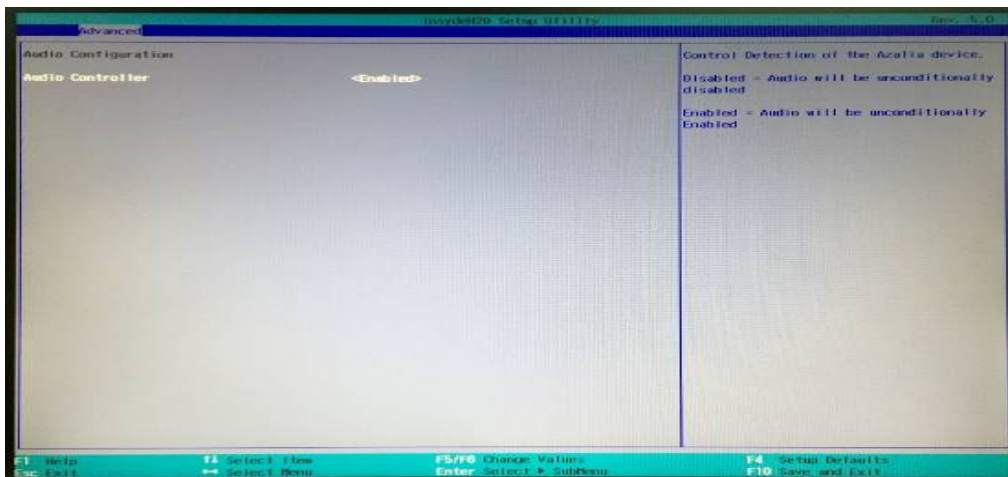

6.1.3. Video Configuration

Use the Video Configuration menu to read Video configuration information and configure the Video settings

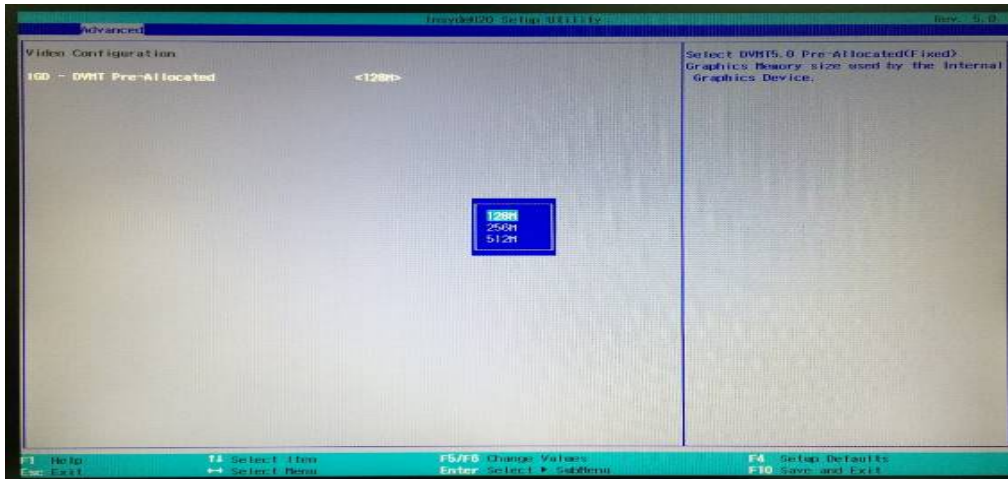

6.1.4. SATA Configuration

Use the SATA Configuration menu to read SATA configuration information and configure the SATA settings

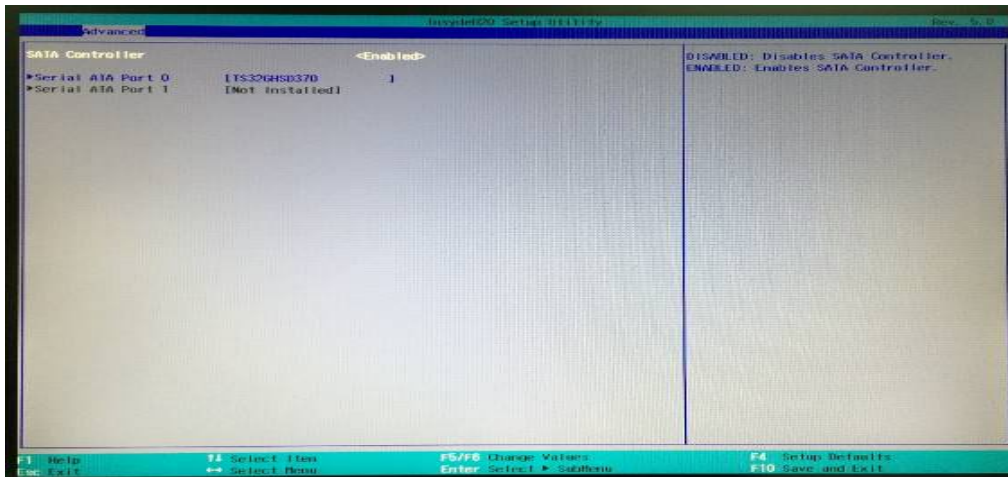

6.2. Security

Use the Security menu to install or change the password

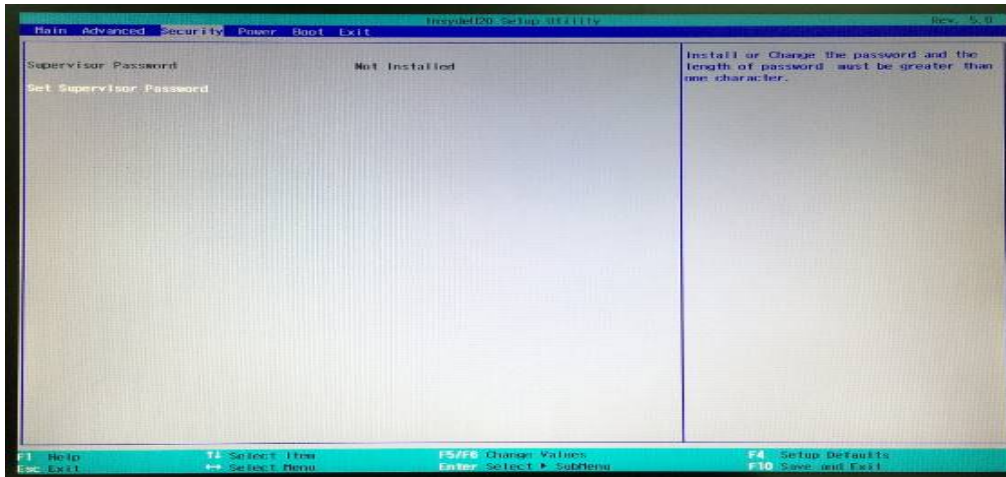

6.3. Power

Use the Power menu to install or change the power settings.

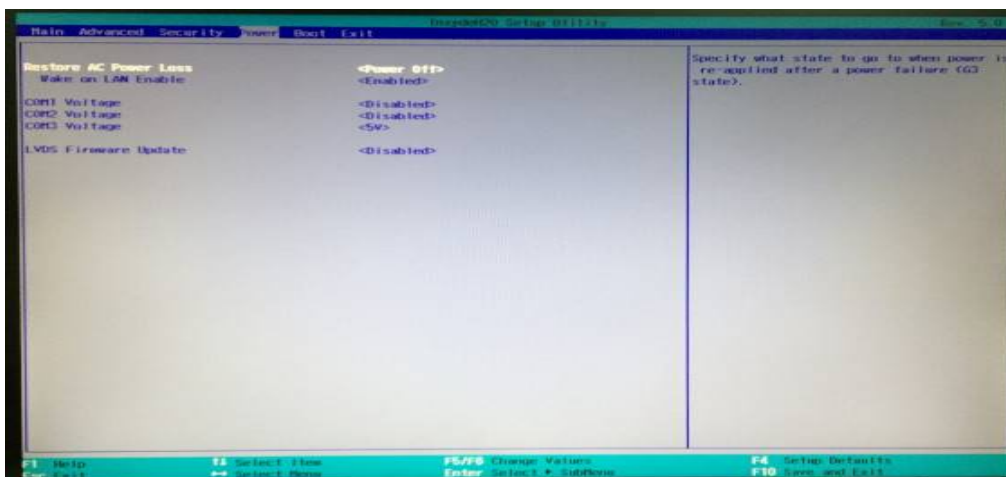

AC Loss Auto Restart: Enable or disable system power on automatically after AC power restored

Wake on LAN: Enable or disable system wake by onboard LAN chip

COM Voltage: This item allows you to select off, 5V or 12V powered COM

LVDS Firmware update: This item allows you to enable or disable LVDS Firmware update

6.4. Boot

Use the Boot menu to select type to Dual type, Legacy type or UEFI type.

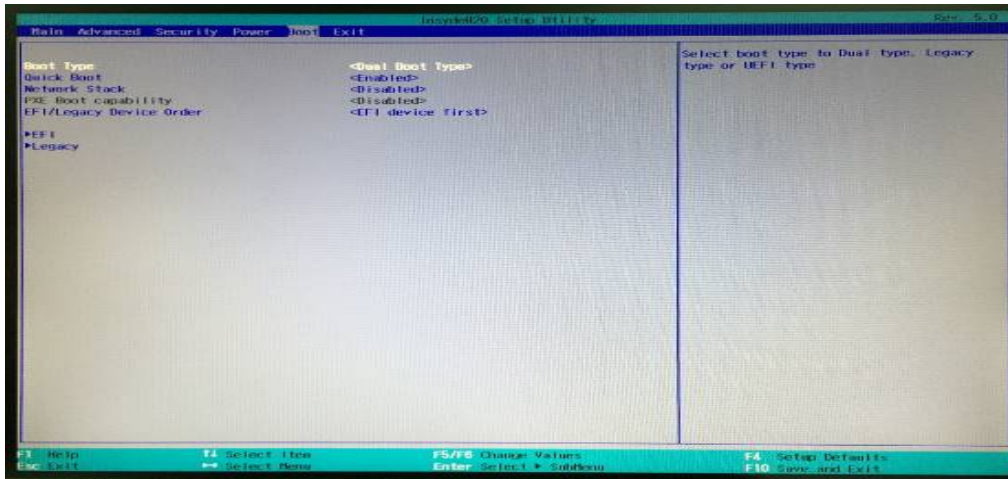

6.5. Exit

Use the Save & Exit menu to load default BIOS values, optimal failsafe values or to save configuration changes.

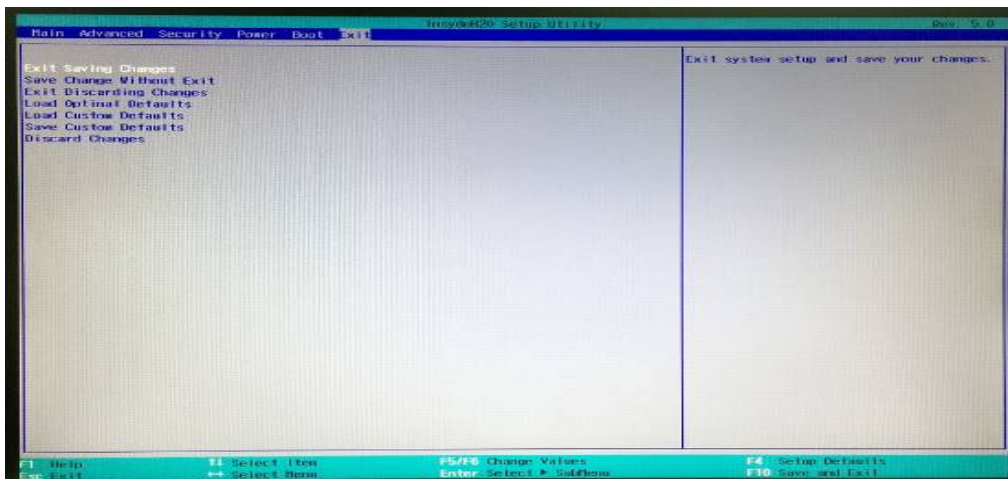

7. LCD Surface Cleaning

1. How to clean the LCD surface properly?

- ✧ Do not spray any liquids on the LCD screen directly, and do not use paper towels, this can cause the LCD screen to become scratched.
- ✧ Always apply the solution to your cloth first, not directly to the parts you are cleaning. You want to avoid dripping the solution directly into your computer or laptop.
- ✧ Stroke the cloth across the display in one direction, moving from the top of the display to the bottom.

2. What are some of the basic supplies needed to clean an LCD screen?

- ✧ A soft cotton cloth. When cleaning the LCD screen it is important to use a soft cotton cloth, rather than an old rag. Some materials, such as paper towels, could cause scratches and damage the LCD screen.
- ✧ Solution of water and isopropyl alcohol. This solution can be used along with the soft cotton cloth.
- ✧ Computer wipes. Only use these if they specifically state on the package they are designed for LCD laptop screens. Computer wipes can come in handy for fast clean-ups or when you want to avoid mixing up a cleaning solution yourself.

3. What types of cleaners are acceptable?

- ✧ Water
- ✧ Vinegar (mixed with water)
- ✧ Isopropyl Alcohol

NOTICE: The following cleaners are unacceptable:

- ✧ Acetone
- ✧ Ethyl alcohol
- ✧ Ethyl acid
- ✧ Ammonia
- ✧ Methyl chloride

CE Notice

This device complies with the requirements of the CE directive.

FCC Notice

This equipment has been tested and found to comply with the limits for a Class B digital device, pursuant to Part 15 of the FCC rules. These limits are designed to provide reasonable protection against harmful interference in a residential installation. This equipment generates uses and can radiate radio frequency energy and, if not installed and used in accordance with the instructions, may cause harmful interference to radio communications. However, there is no guarantee that interference will not occur in a particular installation. If this equipment does cause harmful interference to radio or television reception, which can be determined by turning the equipment off and on, the user is encouraged to try to correct the interference by one or more of the following measures:

Reorient or relocate the receiving antenna.

Increase the separation between the equipment and receiver.

Connect the equipment into an outlet on a circuit different from that to which the receiver is connected.

Consult the dealer or an experienced radio/TV technician for help.

Shielded interface cables must be used in order to comply with emission limits.

Changes or modifications not expressly approved by the party responsible for compliance could void the user's authority to operate the equipment.

WEEE Notice

This appliance is labeled in accordance with European Directive 2002/96/EC concerning waste electrical and electronic equipment (WEEE). The Directive determines the framework for the return and recycling of used appliances as applicable throughout the European Union. This label is applied to various products to indicate that the product is not to be thrown away, but rather reclaimed upon end of life per this Directive.



ZK Building, Wuhe Road, Gangtou, Bantian, Buji Town,
Longgang District, Shenzhen China 518129

Tel: +86 755-89602345

Fax: +86 755-89602394

www.zkteco.com

